

| -1 Float / Phase board [E] | | -2 Relay Board [E] | | -3 Control Board [G] | | -4 Power Supply Board [G] | | -5 Load Board [D] | | -6 ACDC Board [D] | | -7 Front Panel Board [C] | | -8 CT Interface [C] | |
|----------------------------|------------------|--------------------|------------------|----------------------|--------|---------------------------|-------------|-------------------|------------------|-------------------|----------------|--------------------------|--------------------|---------------------|-------------------|
| C1 | 10u | C1 | 0.1u | C1 | 10u | B | 2xCR2032 | D1 | 1N4148 | C1 | 2.2u SMD | LED1 | White 3mm | D1 | 1N4148 SMD |
| C2 | 0.1u | D1 | 1N4148 | C2 | 10n | C1 | 1000u | D2 | 1N4148 | C2 | 0.22u SMD | LED2 | White 3mm | D2 | 1N4148 SMD |
| D1 | 1N4004 | D2 | 1N4148 | C3 | 1u | D1 | W04G Bridge | D3 | 1N4148 | C3 | 0.22u SMD | LED3 | White 3mm | J | USB-A connector |
| D2 | Z 12V/1W | D3 | 1N4148 | C4 | 1u | D2 | 1N4148 | R1 | 4.7k | C4 | 0.1u SMD | LED4 | White 3mm | LED1 | Blue 3mm |
| D3 | Z 12V | D4 | 1N4148 | C5 | 0.1u | DCDC1 | TEP2411 | R2 | 12 | D1 | RB706WM-40 SMD | LED5 | White 3mm | LED2 | Red 3mm |
| D4 | Z 20V | D5 | 1N4148 | R1 | 10k | DCDC2 | TEP2411 | R3 | 12 | D2 | RB706WM-40 SMD | LED6 | White 3mm | R1 | 4.7k, SMD |
| D5 | 1N4004 | D6 | 1N4148 | R2 | 10k | F1 | 500mA F | R4 | 22 | D3 | 1N4148 SMD | LED7 | R/G Bi Color 3mm | R2 | 390 SMD |
| D6 | 1N4148 | D7 | 1N4148 | R3 | 200k | F2 | 500mA F | R5 | 22 | R1 | 20k Trimpot | LED8 | R/G Bi Color 3mm | Re1 | Omron G6K-2F-Y |
| D7 | 1N4148 | D8 | 1N4148 | R4 | 100k | Re1 | V2306 | R6 | 22 | R2 | 22k SMD | R1 | 2.7k SMD | Re2 | Omron G6K-2F-Y |
| D8 | 1N4148 | Re1 | HK 19F-DC 5V-SHG | R5 | 18k | | | Re1 | HK 19F-DC 5V-SHG | R3 | 1k SMD | R2 | 2.7k SMD | SW | Micro Push Button |
| D9 | 1N4004 | Re2 | HK 19F-DC 5V-SHG | R6 | 100k | | | Re2 | HK 19F-DC 5V-SHG | R4 | 47k SMD | Re1 | Omron G6K-2F-Y SMD | | |
| D10 | 1N4004 | Re3 | HK 19F-DC 5V-SHG | R7 | 6.8k | | | Re3 | HK 19F-DC 5V-SHG | Re1 | V23026 | SW1 | Micro Push Button | | |
| D11 | 1N4148 | Re4 | HK 19F-DC 5V-SHG | R8 | 4.7k | | | U1 | 40107B | U1 | 40107B | SW2 | Micro Push Button | | |
| D12 | 1N4148 | Re5 | HK 19F-DC 5V-SHG | R9 | 4.7k | | | U2 | 40107B | | | SW3 | Micro Push Button | | |
| LED7 | R/G BiColor | Re6 | HK 19F-DC 5V-SHG | U1 | CD4013 | | | | | | | SW4 | Micro Push Button | | |
| LED8 | R/G BiColor | Re7 | HK 19F-DC 5V-SHG | U2 | CD4025 | | | | | | | SW5 | Micro Push Button | | |
| Q1 | 2N3904 | Re8 | HK 19F-DC 5V-SHG | U3 | CD4047 | | | | | | | SW6 | DPDT | | |
| Q2 | 2N3904 | U1 | CD4028 | U4 | 74C193 | | | | | | | J | 4p LEMO connector | | |
| R1 | 1.3k SMD | U2 | 40107BE | U5 | CD4028 | | | | | | | | | | |
| R2 | 820/1W | U3 | 40107BE | U6 | CD4049 | | | | | | | | | | |
| R3 | 1k SMD | U4 | 40107BE | U7 | LM555 | | | | | | | | | | |
| R4 | 1.1k SMD | U5 | 40107BE | U8 | CD4073 | | | | | | | | | | |
| R5 | 12k SMD | U6 | CD4075 | U9 | 40107B | | | | | | | | | | |
| R6 | 3.3k | | | | | | | | | | | | | | |
| R7 | 3.3k/1W | | | | | | | | | | | | | | |
| R8 | 1k | | | | | | | | | | | | | | |
| R9 | 1k/1W | | | | | | | | | | | | | | |
| R10 | 47k SMD | | | | | | | | | | | | | | |
| R11 | 1k SMD | | | | | | | | | | | | | | |
| R12 | 1.1k SMD | | | | | | | | | | | | | | |
| Re1 | HK 19F-DC 5V-SHG | | | | | | | | | | | | | | |
| Re2 | HK 19F-DC 5V-SHG | | | | | | | | | | | | | | |
| Re3 | HK 19F-DC 5V-SHG | | | | | | | | | | | | | | |
| Re4 | V23026 | | | | | | | | | | | | | | |
| Re5 | V23026 | | | | | | | | | | | | | | |

Rev A

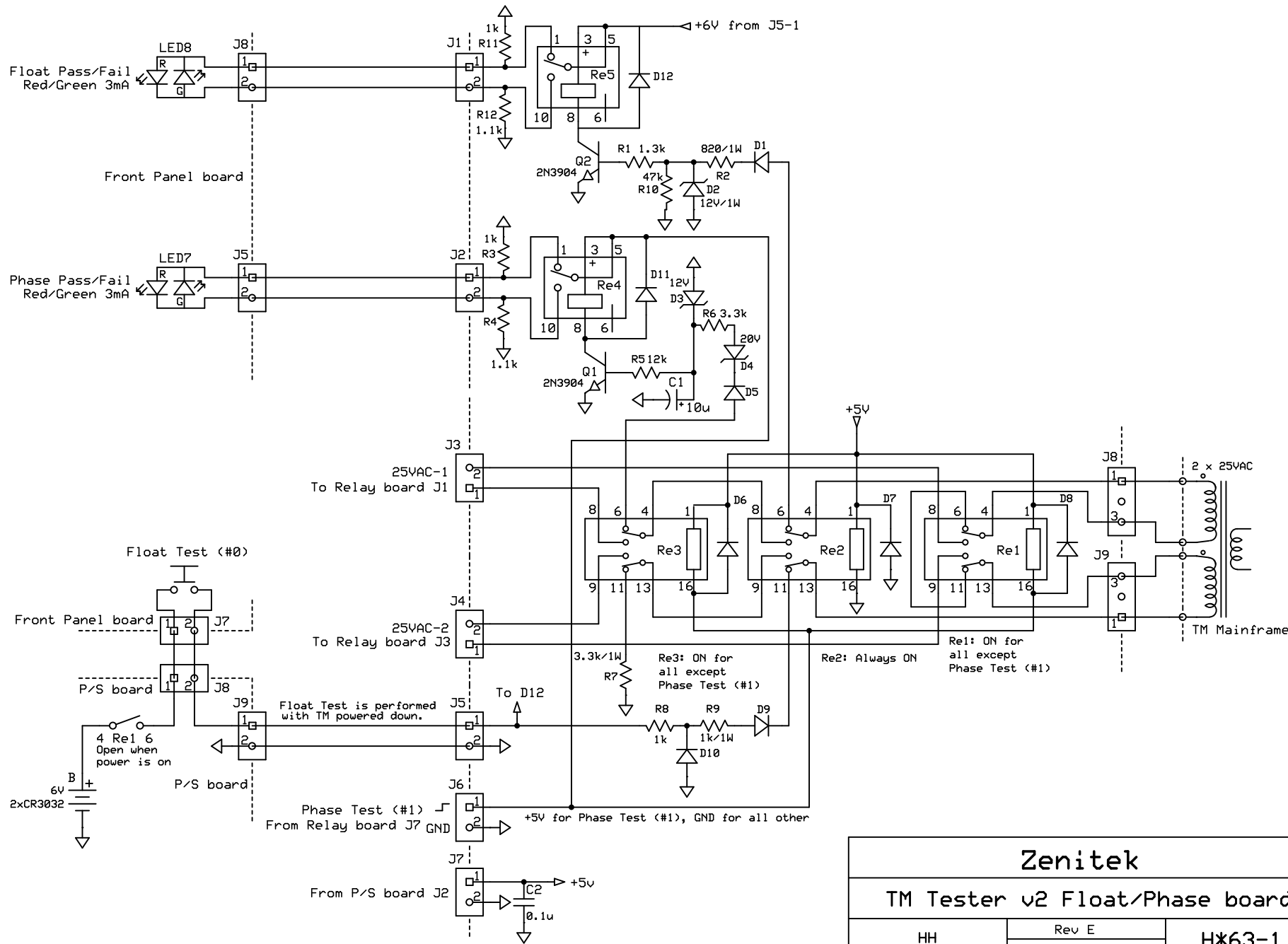

| | | |
|---------------------------------------|---------------------|--------|
| Zenitek | | |
| TM Tester v2 Float/Phase board | | |
| HH | Rev E 2022-03-23 | H*63-1 |

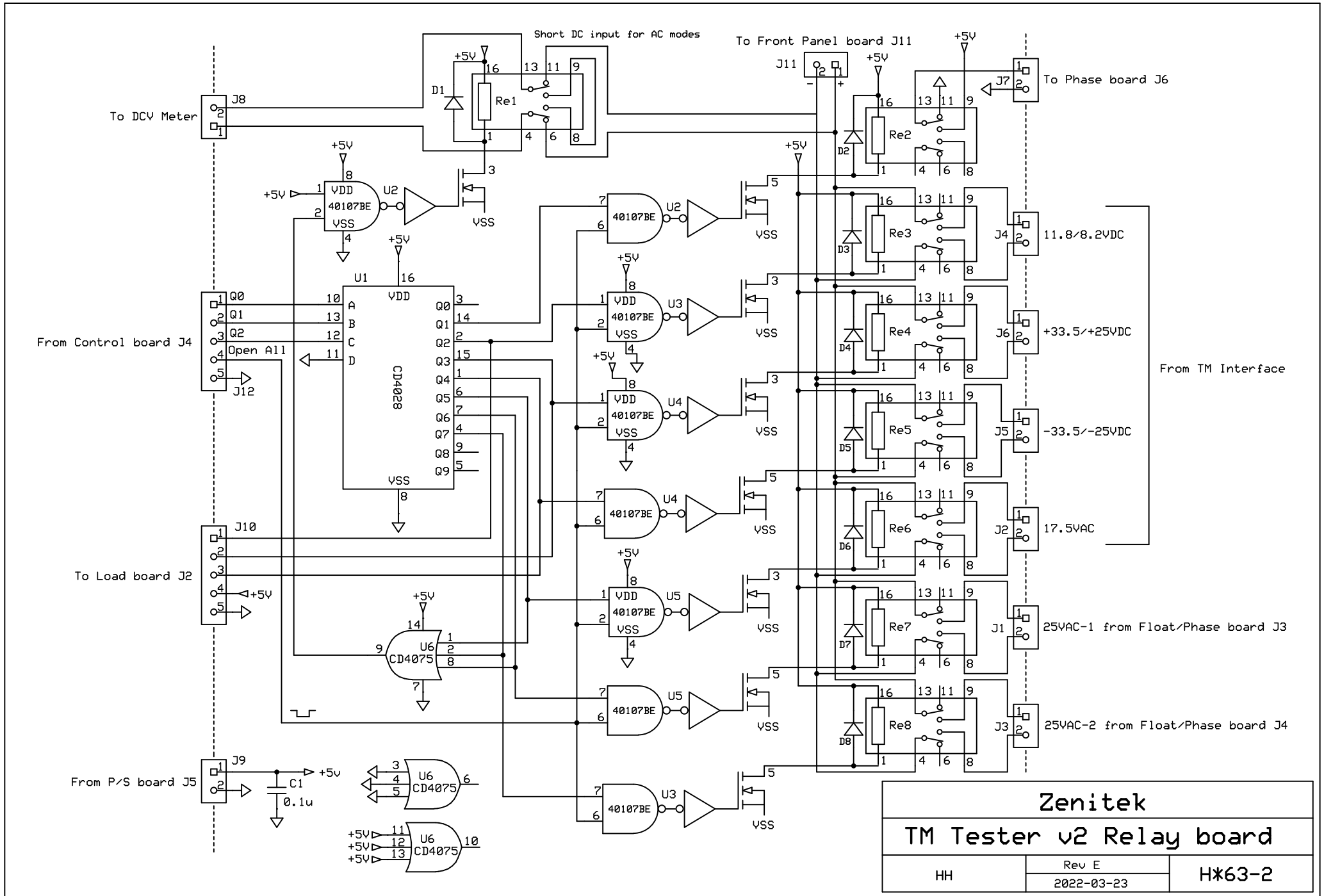

| | | |
|---------------------------------|------------|--------|
| Zenitek | | |
| TM Tester v2 Relay board | | |
| HH | Rev E | HX63-2 |
| | 2022-03-23 | |

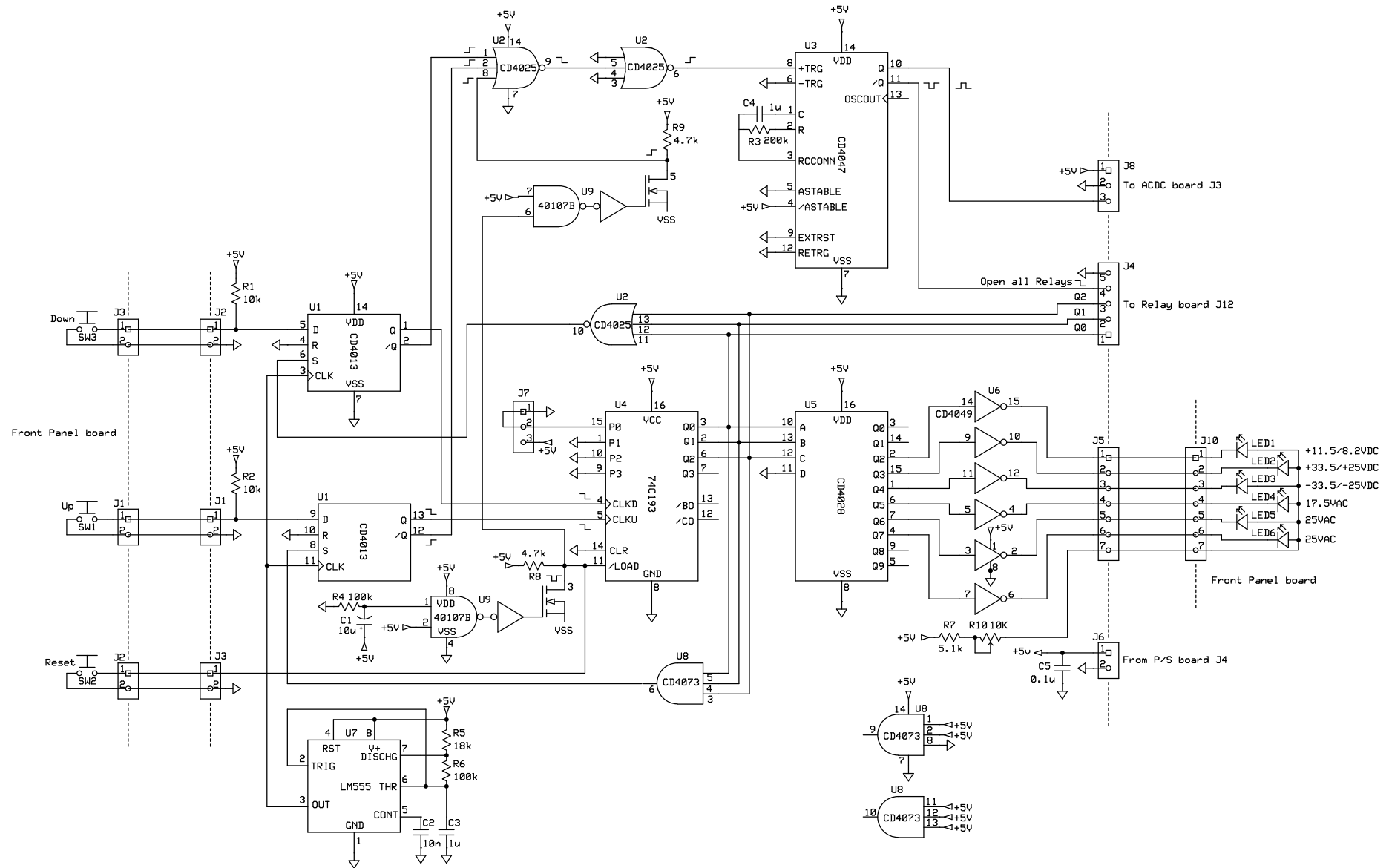

| | | |
|-----------------------------------|---------------------|--------|
| Zenitek | | |
| TM Tester v2 Control board | | |
| HH | Rev H 2022-03-23 | H*63-3 |

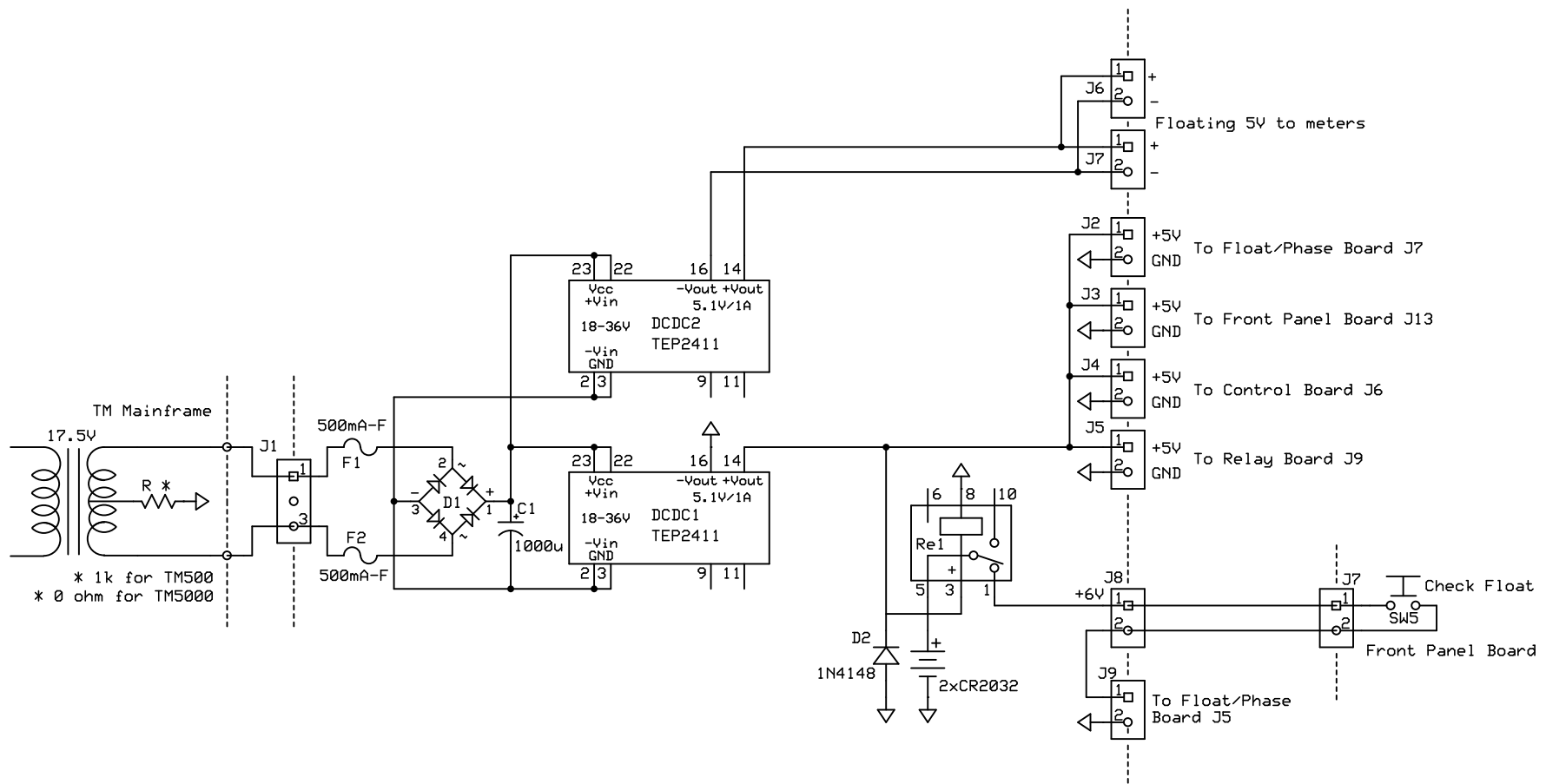

| | | |
|----------------------------------|---------------------|--------|
| Zenitek | | |
| TM Tester v2 Power Supply | | |
| HH | Rev G 2022-03-23 | HX63-4 |

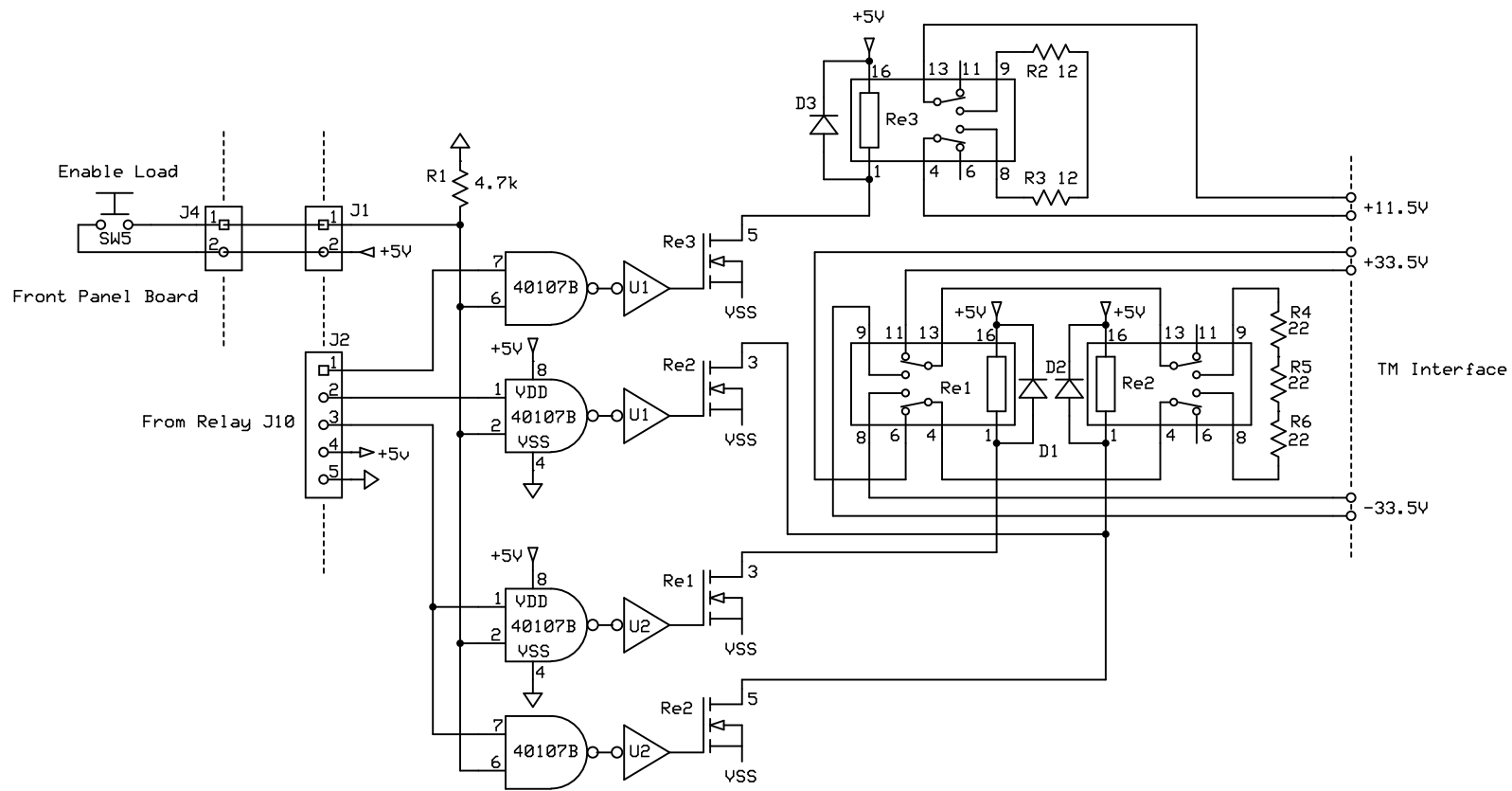

| | | |
|--------------------------------|-------------|--------|
| Zenitek | | |
| TM Tester v2 Load Board | | |
| HH | Rev D | H*63-5 |
| | 2022-03-238 | |

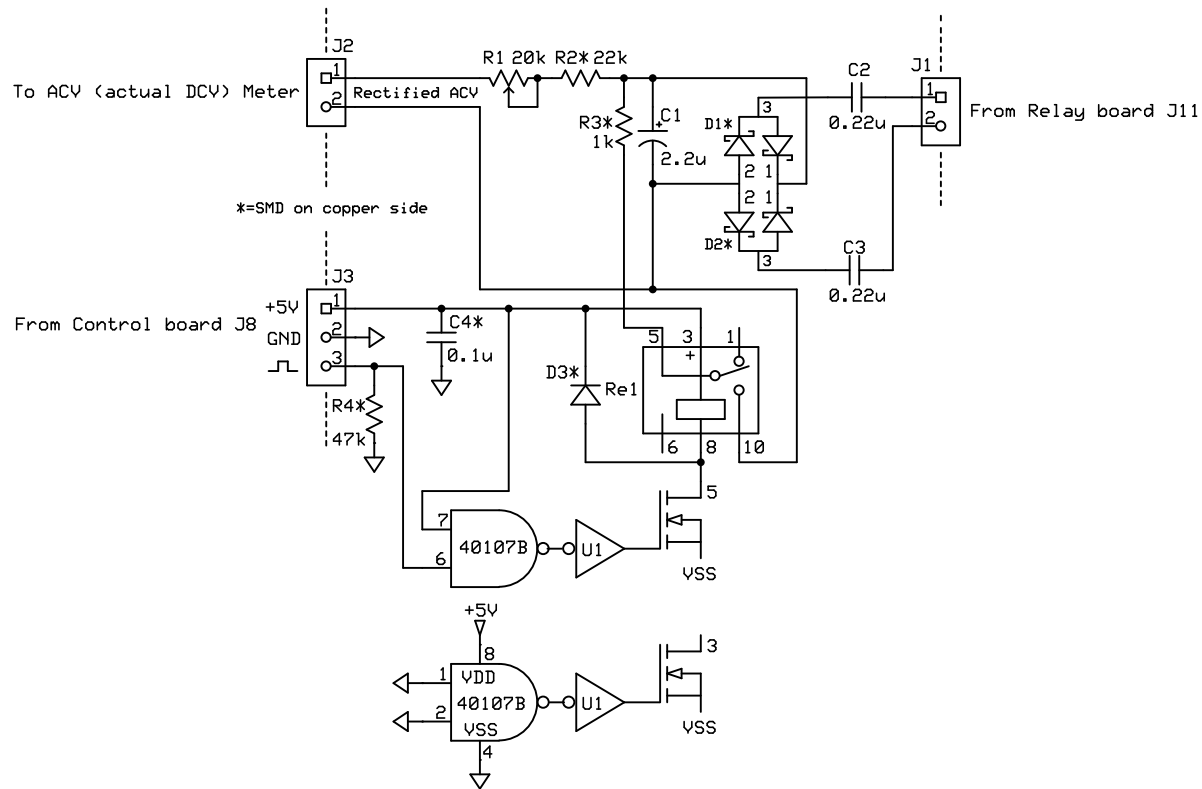

| | | |
|--------------------------------|---------------------|--------|
| Zenitek | | |
| TM Tester v2 ACDC board | | |
| HH | Rev D 2024-08-22 | HX63-6 |

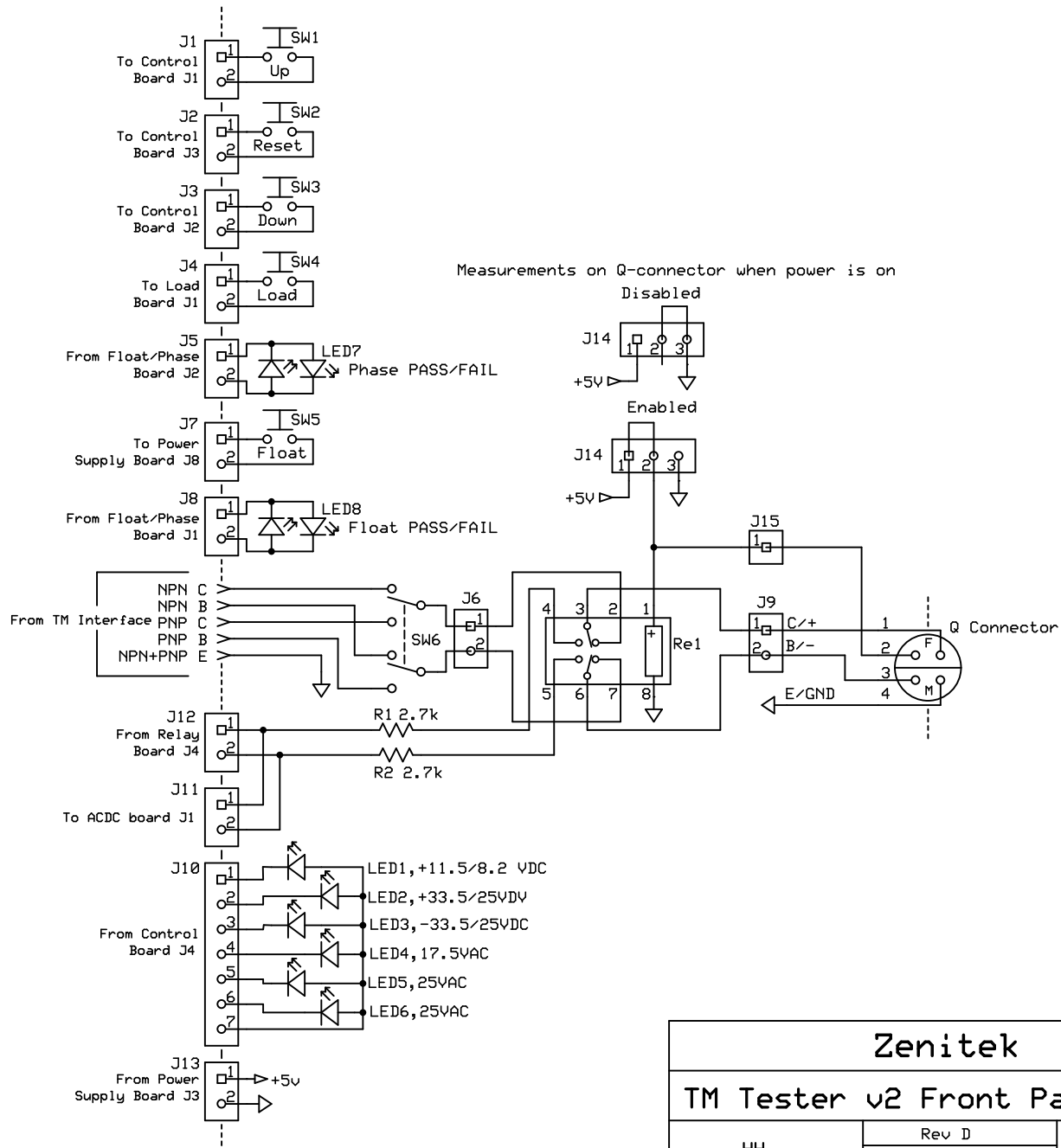

| | | |
|---------------------------------------|---------------------|--------|
| Zenitek | | |
| TM Tester v2 Front Panel Board | | |
| HH | Rev D 2022-03-23 | H*63-7 |

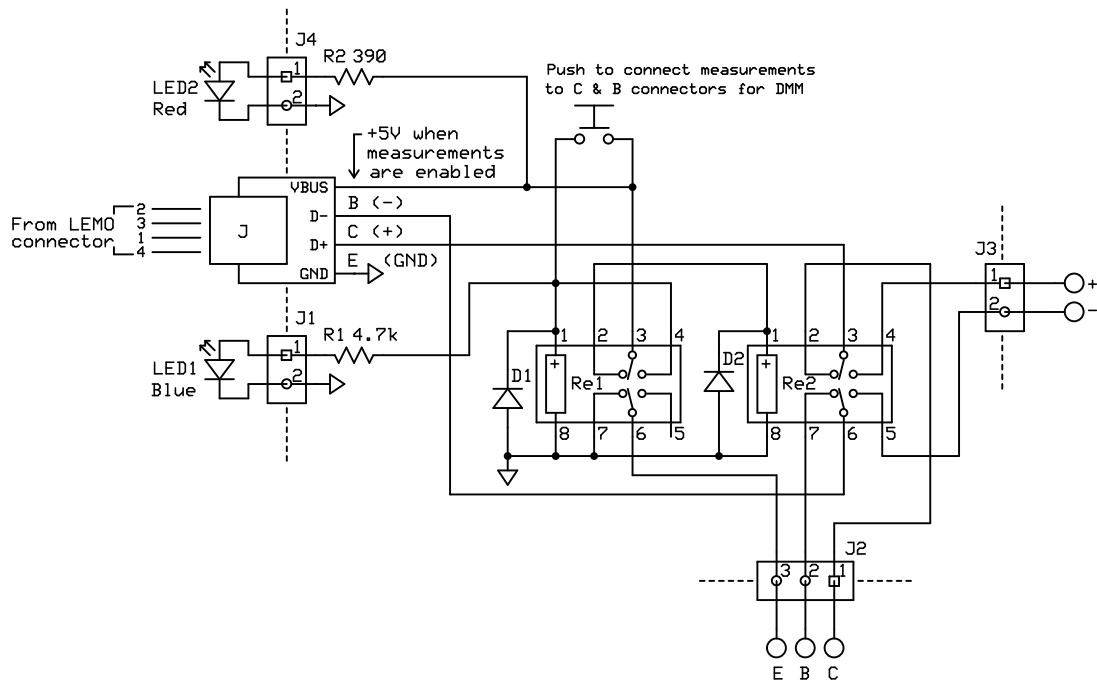

| | | |
|----------------------------------|---------------------|-------|
| Zenitek | | |
| TM Tester v2 CT interface | | |
| HH | Rev C 2022-04-21 | H63-8 |

