



050-1746-00

M48859

## HIGH VOLTAGE CIRCUIT BOARD POST SPACER REPLACEMENT

For TEKTRONIX® 7704A Oscilloscope Systems

Serial Numbers B010100 - B221281

Nylon post spacers, pn 129-0541-00, and aluminum post spacers, pn 129-1031-00, replace nylon post spacers, pn 129-0304-00, and aluminum post spacers, pn 129-0349-00, which are used to mount the High Voltage circuit board. Since the new spacers are longer than the old spacers, replacement of one spacer requires replacement of the remaining four. The longer post spacers are used to reduce the possibility of arcing from the High Voltage circuit board to the rear chassis which may damage one or more resistors on the High Voltage circuit board.

### NOTE

If the serial number of your instrument is greater than those listed above or if this kit has been installed previously, disregard the instructions and use the appropriate post spacer as a direct replacement.

## PARTS INCLUDED IN PARTS REPLACEMENT KIT:

Quantity	Part Number	Description
3 ea	129-0541-00	Spacer, post, 1.53 L, w/4-40 thd, nylon, 0.25 od
2 ea	129-1031-00	Spacer, post, 1.53 L, w/4-40 thd, Al, 0.25 od
1 ea	348-0090-00	Pad, cushioning, 2.03 x 0.69 x 0.312, Si rbr
1 ea		Label, 050-kit

## INSTRUCTIONS:

**WARNING**

*Dangerous shock hazards may be exposed when the instrument covers are removed. Before proceeding, ensure the mainframe power switch is in the off position. Then, disconnect the instrument from the power source. Disassembly should only be attempted by qualified service personnel.*

- ( ) 1. Remove the left and right cabinet sides from the Display Unit.
- ( ) 2. To facilitate access, remove the four screws securing the rear panel on the Display Unit and remove the panel.
- ( ) 3. Remove the three screws securing the High Voltage circuit board cover and remove the cover.

**WARNING**

*Due to stored charges, high voltage potentials may exist in the high voltage circuitry. Using an insulated test lead, dissipate these charges by shorting the high voltage leads and the exposed high voltage points to ground.*

- ( ) 4. Disconnect the CRT anode lead from the high voltage jack. Dissipate any stored charge by grounding the anode lead to the chassis.
- ( ) 5. Disconnect the multipin connectors and coaxial cables from the High Voltage circuit board (A42), noting color codes and locations for later reassembling.
- ( ) 6. Remove the five screws securing the High Voltage circuit board to the mounting post spacers. (The screw securing the lower left corner of the circuit board to the spacer also secures transistor Q50.)

- ( ) 7. Remove the High Voltage circuit board (A42) from the instrument.
- ( ) 8. Disconnect the multipin connectors and coaxial cables from the Z Axis circuit board (A41), noting color codes and locations for later reassembling.
- ( ) 9. Remove the four screws securing the Z Axis circuit board (A41) to the chassis and remove the circuit board.
- ( ) 10. To gain access to the screw securing the lower front post spacer for the High Voltage circuit board (A42), the Display Unit must be separated from the Acquisition Unit as follows (refer to Figure 1):
  - ( ) a. Unplug the Interface Connector located on the right side of the instrument and place it on the storage fixture.
  - ( ) b. Remove the two screws which attach the units on each side and tip the upper edge of the couplings outward.
  - ( ) c. Lift the Display Unit off the Acquisition Unit.
- ( ) 11. Replace the post spacers for the High Voltage circuit board with the post spacers provided in the kit. The two aluminum spacers are used to mount the lower front and rear corners of the High Voltage circuit board. (Instruments below serial number B219100 have a nylon post spacer in the lower rear corner). The new aluminum post spacer provides improved grounding for the High Voltage circuit board A42.
- ( ) 12. Remove the backing from the adhesive side of the cushioning pad, provided in this kit, and apply it directly on top of the existing pad on the high voltage multiplier, U4214 (mounted on the High Voltage circuit board).
- ( ) 13. Reassemble the instrument by performing the reverse of the procedure in steps 2 through 10.
- ( ) 14. Refer to the Calibration section 4 of the Service Manual and make any necessary checks and adjustments.
- ( ) 15. Install the left and right cabinet sides.
- ( ) 16. Remove the protective backing from the 050-kit label, provided in the kit, and apply it to a clean, dry area on the rear panel.
- ( ) 17. For future reference, use the information contained in the kit parts list to update the Replaceable Mechanical Parts section of your Service Manual.

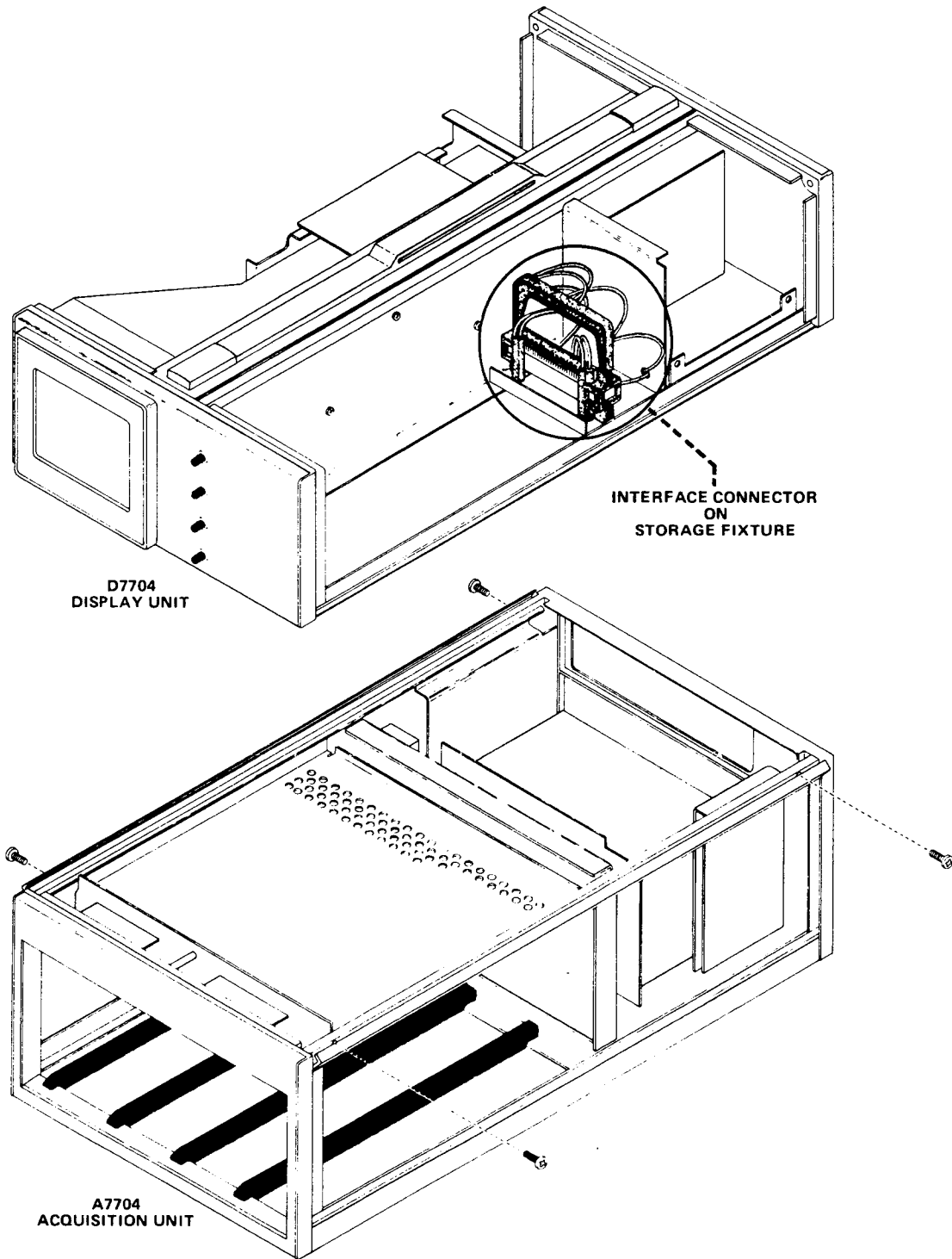

Figure 1. Disassembly of Display and Acquisition Units.